

YZYX130-9结构图

Structure Diagram of YZYX130-9

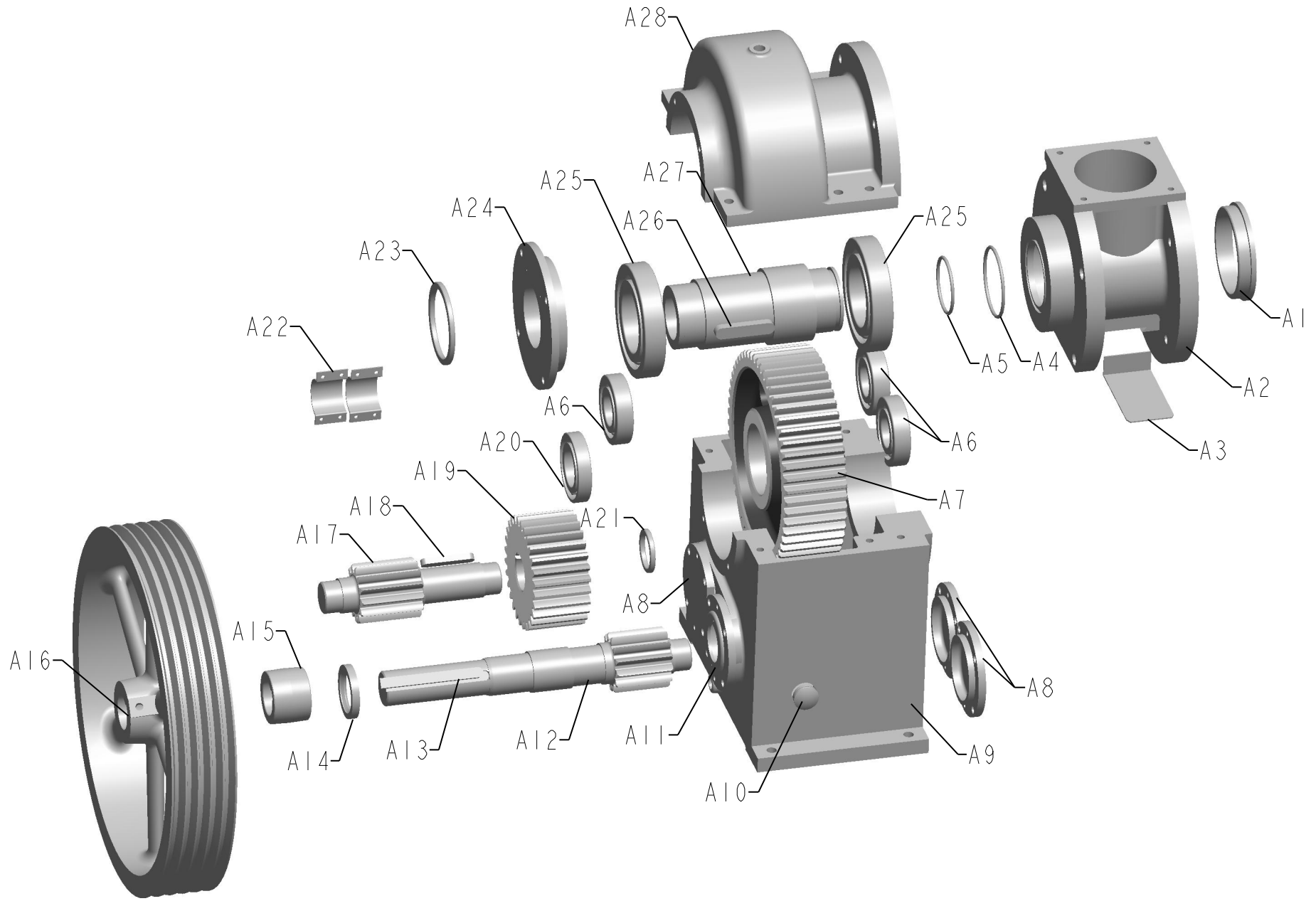

图一 减速箱部件图

Fig.1 Structure Diagram of Gearbox

标号 Item	零件名称 Name	每台数量 Quantity	标号 Item	零件名称 Name	每台数量 Quantity	标号 Item	零件名称 Name	每台数量 Quantity
A1	齿箱套 Gearbox bushing	1	A11	212轴承盖 Bearing cover 212	1	A21	小衬圈 Small bushing	1
A2	进料三通 Feeding base	1	A12	长轴齿轮 Long shaft with gear	1	A22	甩油板 Jilt oil board	1
A3	插销板 Latch plate	1	A13	键C16×160 Key C16×160	1	A23	大衬圈 Large ring	1
A4	O型密封圈109×5.3 O-seal 109×5.3	1	A14	J形油封60×85×12 J-oil seal 60×85×12	1	A24	220轴承盖 Bearing cover 220	1
A5	O型密封圈87.5×5.3 O-seal 87.5×5.3	1	A15	平带轮 Flat belt pulley	1	A25	轴承6220 Bearing 6220	2
A6	轴承NJ310E Bearing NJ310E	3	A16	大带轮 Big belt pulley	1	A26	键20×95 Key 20×95	1
A7	大齿轮 Big gear	1	A17	短轴齿轮 Short shaft with gear	1	A27	空心轴 Hollow shaft	1
A8	310轴承盖 Bearing cover 310	3	A18	键16×85 Key 16×85	1	A28	减速箱盖 Gearbox cover	1
A9	减速箱体 Gearbox body	1	A19	中齿轮 Medium gear	1			
A10	油标A25 Oil scale A25	1	A20	轴承NJ212E Bearing NJ212E	1			

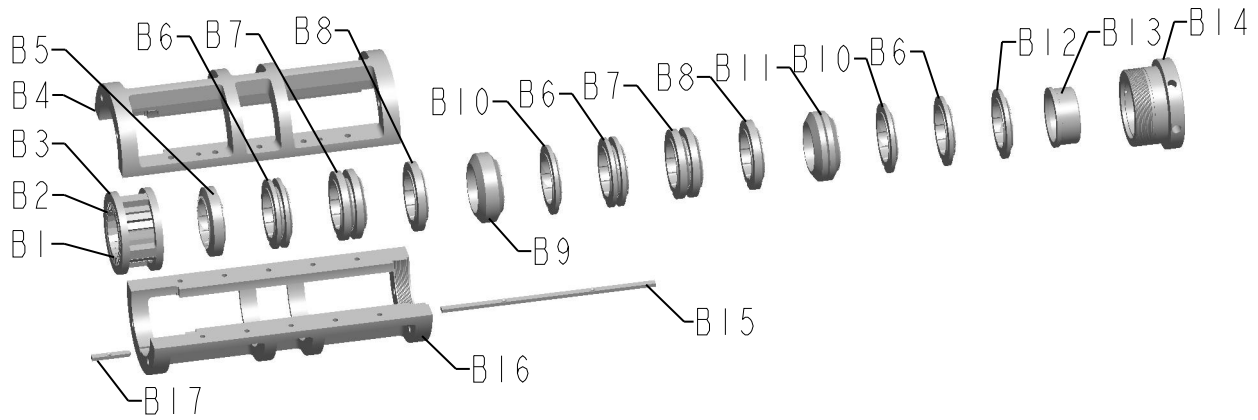

标号 Item	零件名称 Name	每台数量 Quantity	标号 Item	零件名称 Name	每台数量 Quantity
B1	榨条 Squeeze bars	21	B10	6#榨圈 6# Squeeze loop	2
B2	垫片 Spacer	1	B11	A5#榨圈 A5# Squeeze loop	1
B3	榨条圈 The ring for setting up squeeze bars	1	B12	4A#榨圈 4A# Squeeze loop	1
B4	上榨笼 Top cage	1	B13	出饼圈 The loop for cakes out	1
B5	1#榨圈 1# Squeeze loop	1	B14	压紧螺栓 Pressing bolt	1
B6	2#榨圈 2# Squeeze loop	5	B15	平键 B16×580 Key B16×580	1
B7	3#榨圈 3# Squeeze loop	4	B16	下榨笼 Bottom cage	1
B8	4#榨圈 4# Squeeze loop	2	B17	平键 C16×105 Key C16×105	1
B9	5#榨圈 5# Squeeze loop	1			

图二 榨膛部件图

Fig.2 Structure Diagram of Squeeze Cage and Squeeze Loops

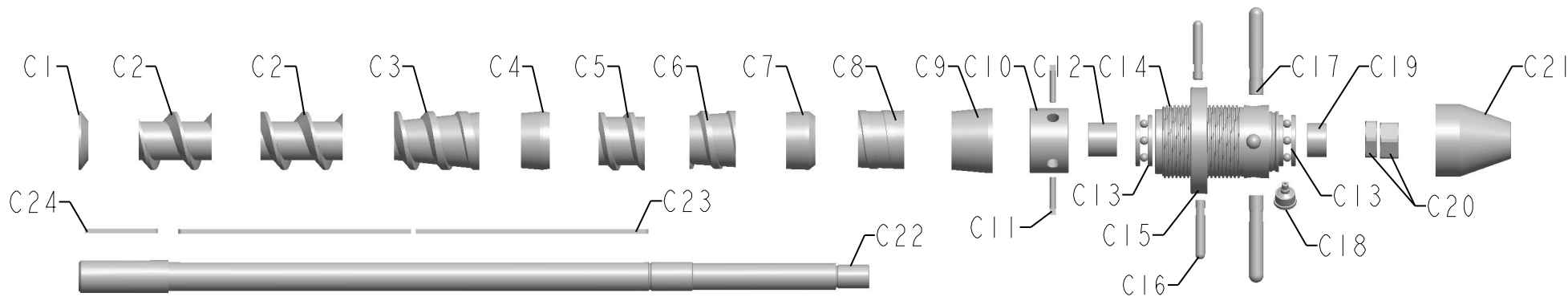

标号 Item	零件名称 Name	每台数量 Quantity	标号 Item	零件名称 Name	每台数量 Quantity	标号 Item	零件名称 Name	每台数量 Quantity
C1	挡圈 Spacing collar	1	C9	出渣头 The spiral for cakes out	1	C17	大手柄 Big handle	4
C2	1、2#榨螺 1、2# Squeeze spiral	2	C10	锁紧螺母 Lock nut	1	C18	油杯A25 Oil cup A25	1
C3	3#榨螺 3# Squeeze spiral	1	C11	螺栓M12×65 Bolt M12×65	2	C19	短含油轴承 Short oil-retaining bearing	1
C4	4#榨螺 \varnothing 90 4# Squeeze spiral \varnothing 90	1	C12	长含油轴承 Long oil-retaining bearing	1	C20	薄、厚螺母 Thin/ Thick nut	各1
C5	-9型5#榨螺 -9 type 5# Squeeze spiral	1	C13	轴承51311 Bearing 51311	2	C21	防护帽 Safety cover	1
C6	-9型6#榨螺 -9 type 6# Squeeze spiral	1	C14	调节螺栓 Adjusting bolt	1	C22	总轴 Main shaft	1
C7	-9型4#榨螺 \varnothing 115 -9 type 4# Squeeze spiral \varnothing 115	1	C15	夹紧圈 Tight nut	1	C23	平键 B16×480 Key B16×480	2
C8	-9型7#榨螺 -9 type 7# Squeeze spiral	1	C16	小手柄 Small handle	2	C24	平键 C16×150 Key C16×150	1

图三 螺旋轴部件图

Fig.3 Structure Diagram of Spiral Shaft

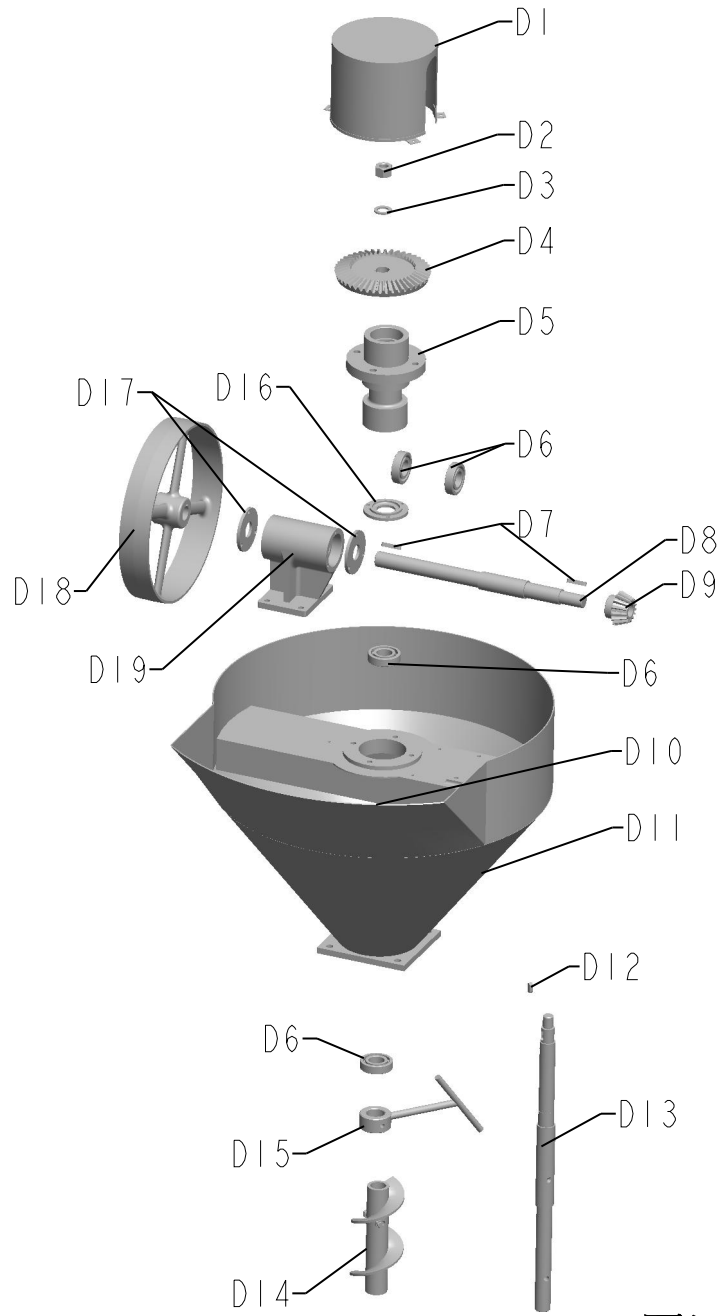

标号 Item	零件名称 Name	每台数量 Quantity	标号 Item	零件名称 Name	每台数量 Quantity
D14	压料螺旋 Feeding screw	1	D1	防护罩 Safety cover	1
D15	拨料杆 Stir device	1	D2	M20六角螺母 M20 Hexagon nut	1
D16	轴承盖(二) Bearing cover No.2	1	D3	平垫圈 Gaskets	1
D17	轴承盖(一) Bearing cover No.1	2	D4	大锥齿轮 Big bevel gear	1
D18	皮带轮 Belt pulley	1	D5	轴承座 (2) Bearing support No.2	1
D19	轴承座 (1) Bearing support No.1	1	D6	轴承6206 Bearing 6206	4
			D7	平键 A8×40 Key A8×40	2
			D8	传动轴 Transmission shaft	1
			D9	小锥齿轮 Small bevel gear	1
			D10	轴承51206 Bearing 51206	1
			D11	料斗 Hopper	1
			D12	平键 A8×20 Key A8×20	1
			D13	进料轴 Feeding shaft	1

图四 进料机构部件图

Fig.4 Structure Diagram of Feeding Hopper

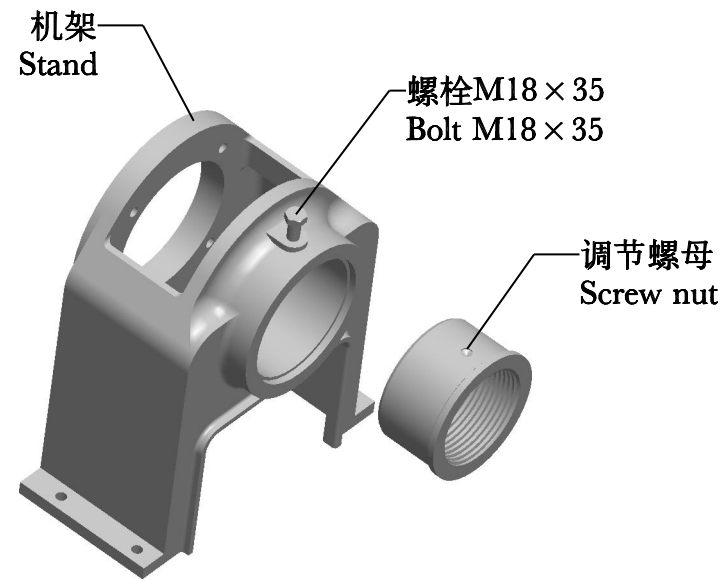

图五 机架部件图

Fig.5 Structure Diagram of Machine Stand